



Construction

Close-coupled peripheral pump (regenerative pump) with turbine impeller. Compact, patented construction with movable casing cover motor side (replaceable in case of wear)
Protected against water entering the motor from outside.

Applications

For clean liquids without abrasives, without suspended solids, non-explosive, non-aggressive for the pump materials.
For increasing network pressure (follow local specifications).
For the reduced dimensions, these pumps are very well suitable to be mounted in cooling and air-conditioning machines and equipments, circulation.

Operating conditions

Liquid temperature up to 60 °C.
Ambient temperature up to 40 °C.
Total suction lift up to 7 m.
Continuous duty.

Motor

2-pole induction motor, 50 Hz (n = 2900 rpm).

CT 61: three-phase 230/400 V ± 10%.

CTM 61: single-phase 230 V ± 10%, with thermal protector.
Capacitor inside the terminal box.

Insulation class F.

Protection IP 54.

Constructed in accordance with: EN 60335-2-41.

Materials (wetted parts)

Components	CT 61	B-CT 61
Pump casing	Cast iron GJL 200 EN 1561	Bronze G-Cu Sn 10 EN 1982
Casing cover motor side	Brass P- Cu Zn Pb 2 UNI 5705	
Impeller	Brass P- Cu Zn Pb 2 UNI 5705	
Shaft	Chrome steel AISI 430	
Mechanical seal	Carbon - Ceramic - NBR	

Special features on request

- Other voltages.
- Frequency 60 Hz (as per 60 Hz data sheet).
- Special mechanical seal.

Coverage chart n ≈ 2900 rpm

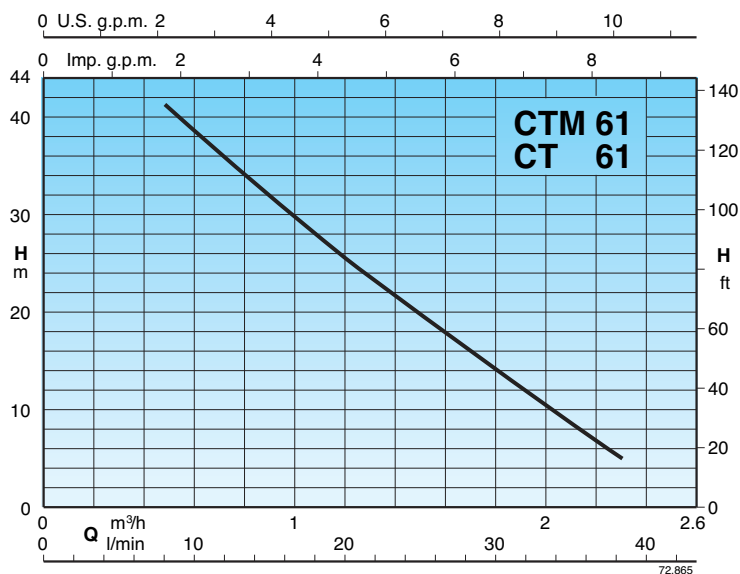

Performance $n \approx 2900$ rpm

3~	230V 400V		1~	230V	P ₂		Q	Flow Rates							
	A	A			kW	HP		m ³ /h	0,48	0,6	0,75	0,96	1,2	1,5	1,89
CT 61	1,9	1,1	CTM 61	2,5	0,33	0,45	H m	41	38,5	35,5	31	25,5	19	11	5
B-CT 61			B-CTM 61												

H Total head in m.

P₂ Rated motor power output.

Dimensions and weights

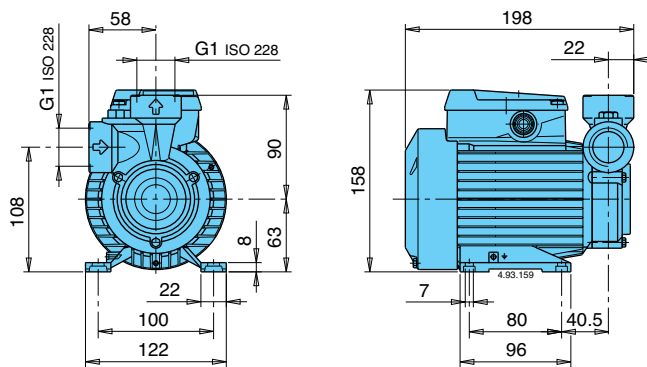

CT 61 **4,9** kg
 CTM 61 **5** kg
 B-CT 61 **5,1** kg
 B-CTM 61 **5,2** kg

Features

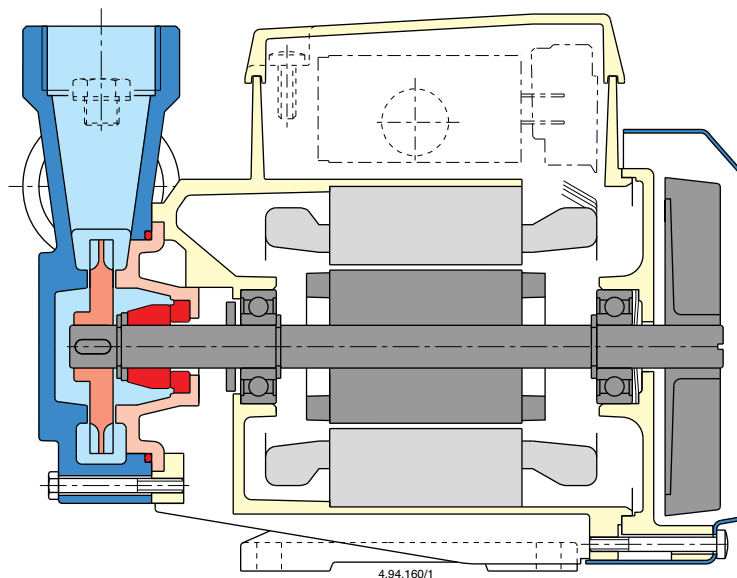

Patented

4.94.160/1