



Construction

Close-coupled self-priming shallow-well jet pump with built-in ejector.

Applications

For drawing water out of a well.
 For lifting water containing air or other gases.
 For increasing water pressure from flooded suction applications.
 As pressure boosting pump for central water systems with low pressure (follow local specifications if increasing network pressure).
 For garden use.
 For washing with a jet of water.

Operating conditions

Liquid temperature: 0 °C to +35 °C.
 Ambient temperature up to +40 °C.
 Suction lift up to 9 m.
 Maximum permissible pressure in the pump casing: 8 bar.
 Continuous duty.

Materials

Component	Material
Pump casing	Cast iron GJL 200 EN 1561
Casing cover	Cr-Ni steel 1.4301 EN 10088 (AISI 304)
Impeller	Brass P-Cu Zn 40 Pb 2 UNI 5705
Wear ring impeller-diffuser	Cr-Ni steel 1.4301 EN 10088 (AISI 304)
Diffuser	PPO-GF20 (Noryl)
Ejector	PPO-GF20 (Noryl)
Shaft	Chrome steel 1.4104 EN 10088 (AISI 430)
Mechanical seal	Carbon - Ceramic - NBR

Motor

2-pole induction motor, 60 Hz ($n \approx 3450$ rpm).

NGL: three-phase 220/380 V.

NGLM: single-phase 220 V, with thermal protector.
 Capacitor inside the terminal box.

Insulation class F.

Protection IP 54.

Constructed in accordance with: EN 60335-2-41.

Characteristic curve $n \approx 3450$ rpm

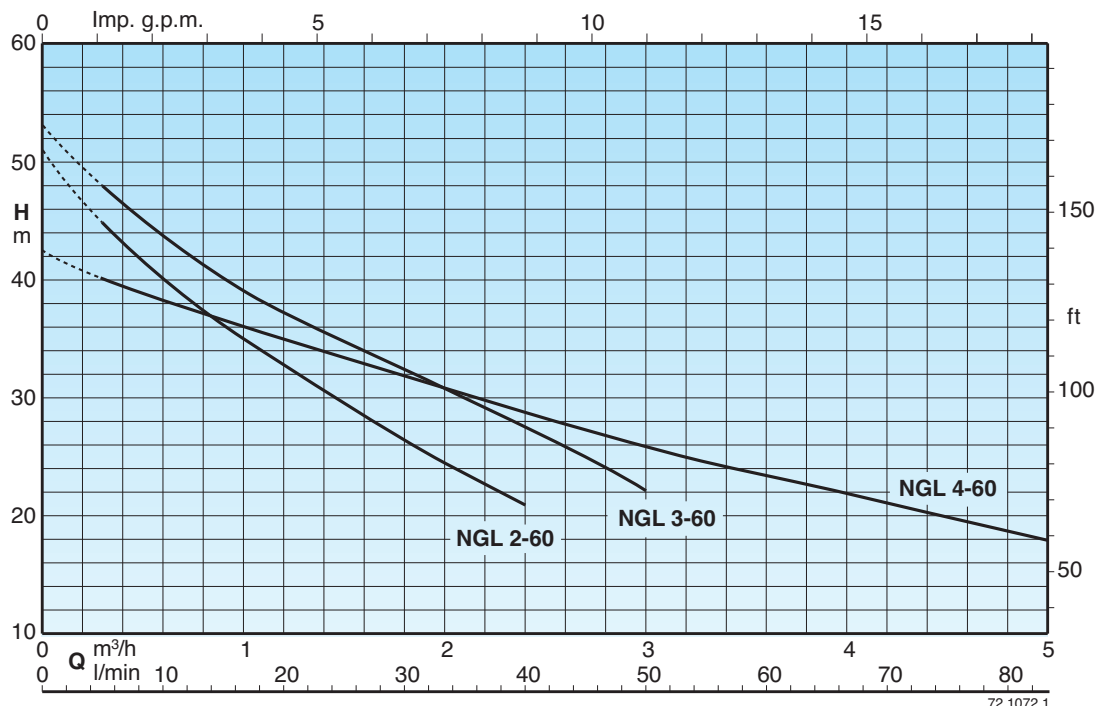

72.1072.1

Technical data $n \approx 3450$ rpm

3~	220V 380V			1~	220V		P1	P2			Q									
	A	A	IA/IN		A	IA/IN		kW	kW	HP		m ³ /h	0	0,3	1	2	2,4	3	4	4,5
NGL 2-60	3,5	2	4,8	NGLM 2-60	4,1	3	0,8	0,45	0,6	H m	0	5	16,6	33,3	40	50	66,6	75	83,3	
NGL 3-60/A	3,3	1,9	4,3	NGLM 3-60/A	5	3,3	0,95	0,55	0,75		51	45	35	24,5	21					
NGL 4-60/A	4,2	2,4	4,8	NGLM 4-60/A	6,2	3,2	1,1	0,75	1		53	48	39,5	31	28	22				
											42,5	40	36	31	29	26	22	20	18	

P1 Max. power input.

P2 Rated motor power output.

IA/IN = D.O.L. starting current / Rated current

Tolerances according to ISO 9906, annex A.

Characteristic Curves for different suction lifts H_s

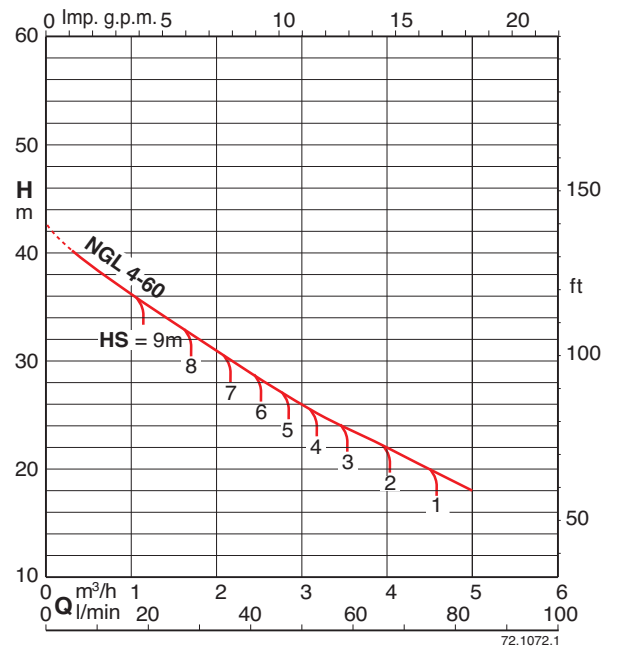
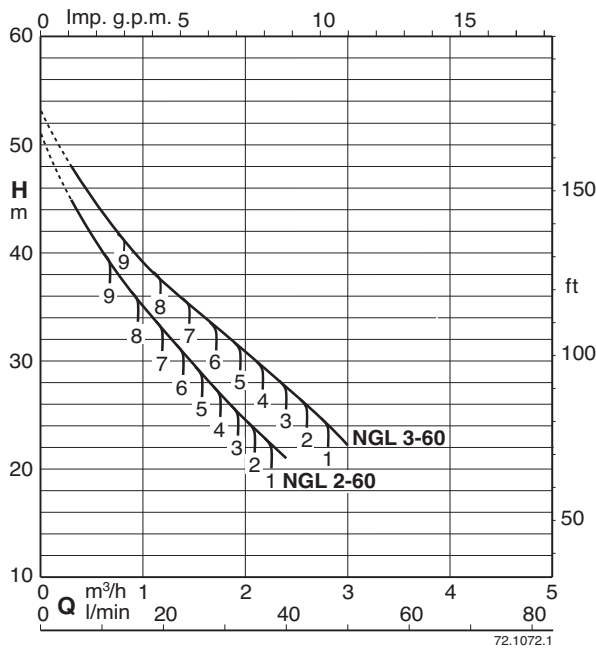

Self-priming capability

60 Hz ($n \approx 3450$ 1/min), H_2O , $T = 20^\circ C$, $P_a = 1000$ hPa (mbar)

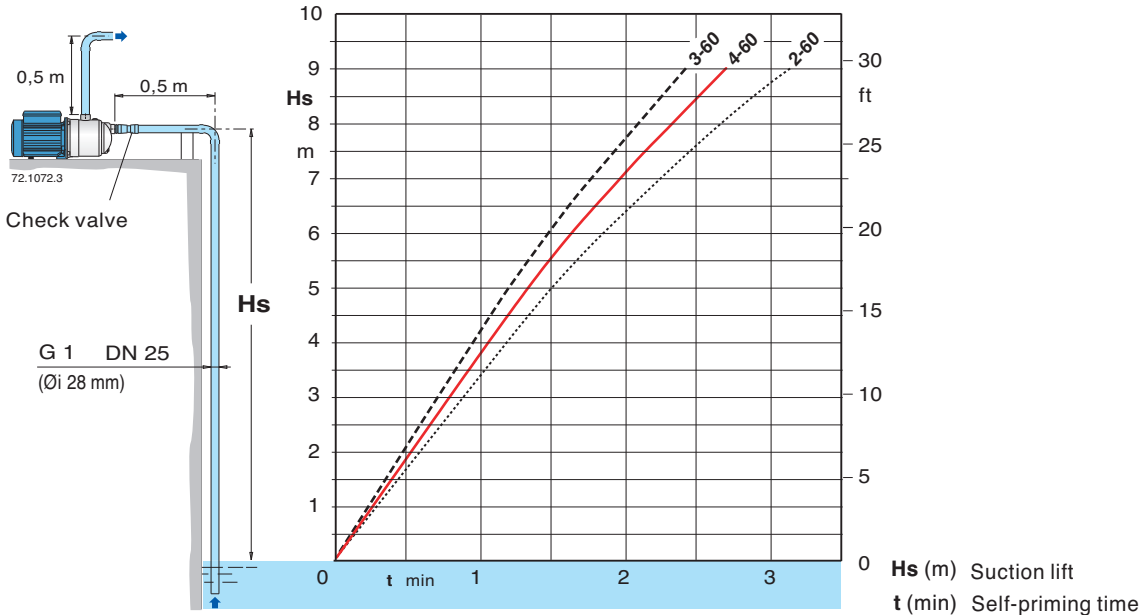

Dimensions and weights

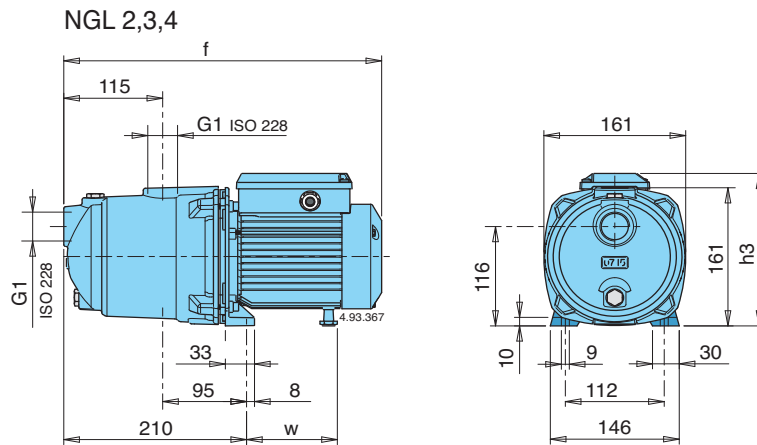

TYPE	Dimensions mm			Net weight kg	
	f	h3	w	NGL	NGLM
NGL 2-60	362	176	102	10,5	10,5
NGL 3-60/A	391	192	112	11,7	12,6
NGL 4-60/A	391	192	112	12,6	13,6

Features

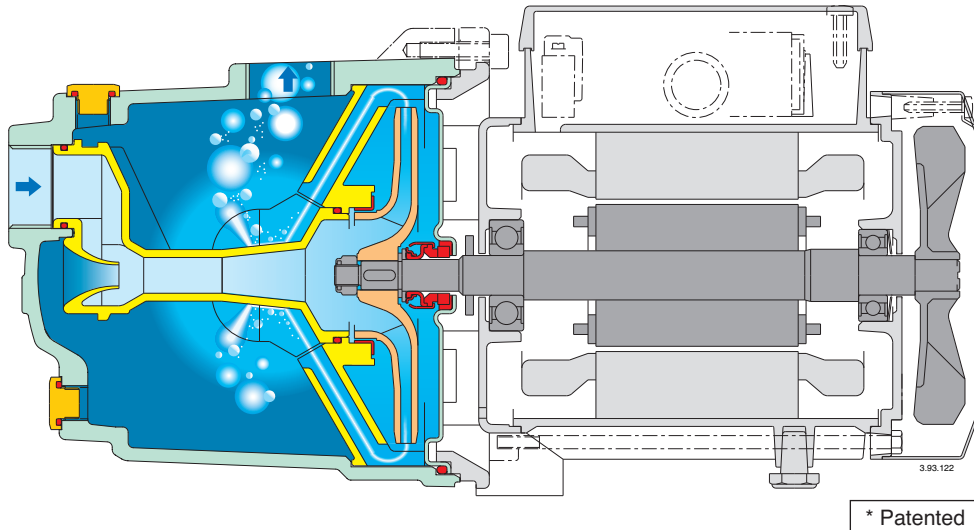

A different jet pump with new features

Not just another jet pump.

An exclusive diffuser design with flow control device* provides for compact construction, fast self-priming capability and low noise.

Reliable

With new design features the NGL is more robust and forgiving when temporary abnormal operating conditions may exist.

Compact

The NGL is smaller than conventional pumps of a similar type, allowing for installation in restricted spaces and providing for easier retrofit applications.

Safe

Fast air evacuation reduces the risk of air-pockets developing at the mechanical seal preventing the danger of seal failure due to a lack of flushing and cooling.

Better self-priming

The NGL are capable of lifting water from depths of 9 m in less than 3 minutes, offers new possibilities on suction lift applications and provides better trouble free service on normal shallow-well suction lift duties, also with a long suction pipe above the water level.

Low noise

The new diffuser and flow control device* guide the fluid from the impeller into the central part of the pump casing, reducing turbulence and velocity, with effective use of the surrounding liquid in dampening the noise of flow.